

Bilkent University  
Department of Electrical and Electronics Engineering  
**EEE 313 Electronic Circuit Design**

**Experiment 1**  
**Coupling Capacitors**

**Theory**

In various electronic circuits, it is necessary to combine or separate AC and DC voltages or currents from each other. This task is usually accomplished with the use of capacitors. These so called *coupling capacitors* ideally behave as open circuits for DC voltages and short circuits for AC signals that are above a certain frequency.

Consider the following simple  $RC$  circuit.

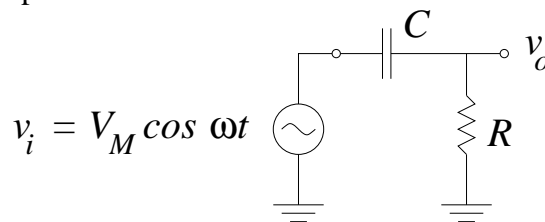

The impedance of the capacitor is  $Z_c = 1/j\omega C$ . For a sinusoidal input signal at angular frequency  $\omega$ , the input and output phasors are related by

$$V_o = \frac{R}{R + Z_c} V_i = \frac{j\omega RC}{1 + j\omega RC} V_i.$$

Looking at this expression, we see that when  $\omega RC \gg 1$  the unity term in the denominator can be neglected and  $V_o \simeq V_i$ . In other words, at frequencies  $f$  that are much larger than the *corner frequency*  $f_c = 1/2\pi RC$ , the impedance of the capacitor becomes small enough to be neglected, and hence it is said to behave like a short circuit. On the other hand, for DC voltages  $\omega = 0$  and we have  $V_o = 0$ , i.e., the capacitor behaves like an open circuit.

There is of course a range of frequencies for which the capacitor is neither an open nor a short circuit. We can manipulate the above expression into a form

$$V_o = \frac{1}{\sqrt{1 + (f_c/f)^2}} \exp j[\pi/2 - \tan^{-1}(f/f_c)] V_i$$

so that the amplitude and the phase of the output voltage phasor can be easily identified.

The overall frequency behavior is best demonstrated with a Bode plot, i.e., a graph of the relative output voltage amplitude versus frequency. Note that it is customary to use a logarithmic scale

for both axes in Bode plots, a relative dB scale for the vertical axis and a logarithmic scale for the horizontal frequency axis. The deciBell (dB) is a logarithmic and relative unit, commonly used to express ratios of voltages or currents. For example, the *voltage gain*  $A_v = |V_o|/|V_i|$  of a circuit is the ratio of the output to the input voltage phasor magnitude. The linear voltage gain  $A_v$  is related to the voltage gain in dB units by

$$A_{v,dB} = 20 \log A_v .$$

If  $A_v = 1$  then  $A_{v,dB} = 0$  dB, i.e., unity gain corresponds to 0 dB. If  $A_v = 1/\sqrt{2}$  then  $A_{v,dB} = -3$  dB. Since electrical power is proportional to the square of the voltage or the current, power gain  $G$  is converted to dB units using

$$G_{dB} = 10 \log G .$$

Unity power gain also corresponds to 0 dB, however,  $G_{dB} = -3$  dB corresponds to  $G = 0.5$ .

In our circuit, for  $f \gg f_c$  the capacitor is practically a short circuit, and the output is 0 dB relative to the input. At the corner frequency  $f_c$ , we have  $|Z_c| = R$  and  $|V_o| = |V_i|/\sqrt{2}$ . In dB scale, the value of the output voltage at  $f = f_c$  is  $20 \log(1/\sqrt{2}) = -3$  dB relative to the input voltage. It is important to note that for  $f \geq 4f_c$ , the error made by assuming the capacitor to be a short circuit is always less than 3% (0.26 dB). The output amplitude decreases at a rate of 20 dB/decade for frequencies that are much less than the corner frequency.

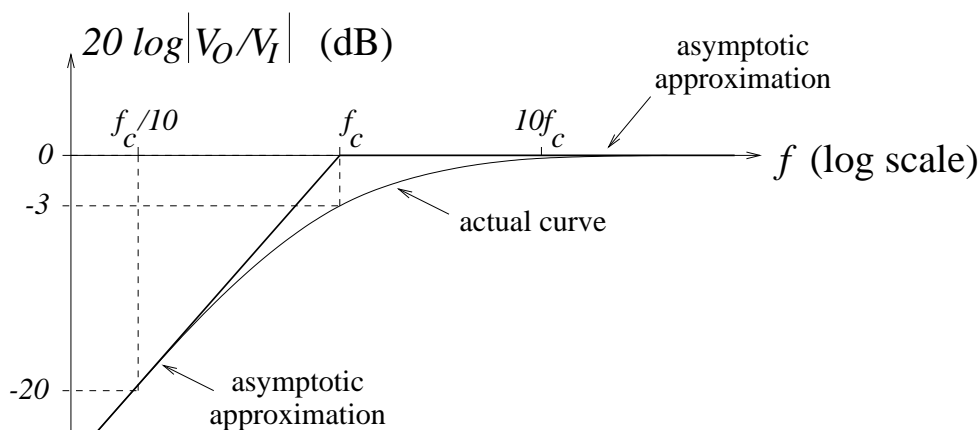

The phase term in the expression above shows that for  $f \gg f_c$  the output is in phase with the input, since  $[\pi/2 - \tan^{-1}(f/f_c)] \simeq 0$  in this case. At lower frequencies there is a frequency dependent phase shift between the input and the output.

Now consider the following circuit.

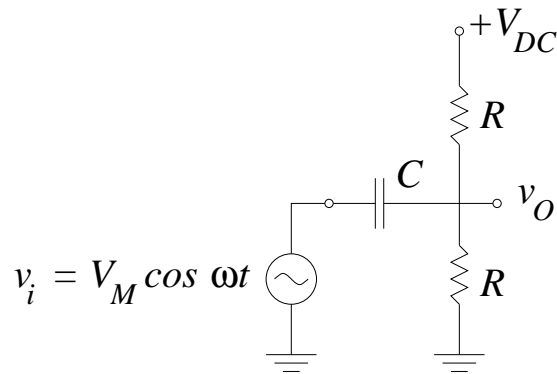

Note that this circuit is linear and the superposition principle can be used. This means that to find the output voltage  $v_o$ , we can solve the circuit for each voltage source separately (considering all other independent voltage sources to be short circuit and current sources to be open circuit), and then add the results.

The newly added DC voltage supply does not affect the signal source, since the capacitor is an open circuit for DC voltages. In other words, there is no DC current going through the AC signal source. The output voltage  $v_o = V_O + v_o$  is now the sum of a DC and an AC component. We see that the DC component is simply  $V_O = V_{DC}/2$ , since the two resistors form a voltage divider. On the other hand, as far as AC signals are concerned, the capacitor is a short circuit (assuming  $f \gg f_c$ ) and the DC voltage supply is also a short circuit (using superposition principle). Hence the AC equivalent circuit becomes:

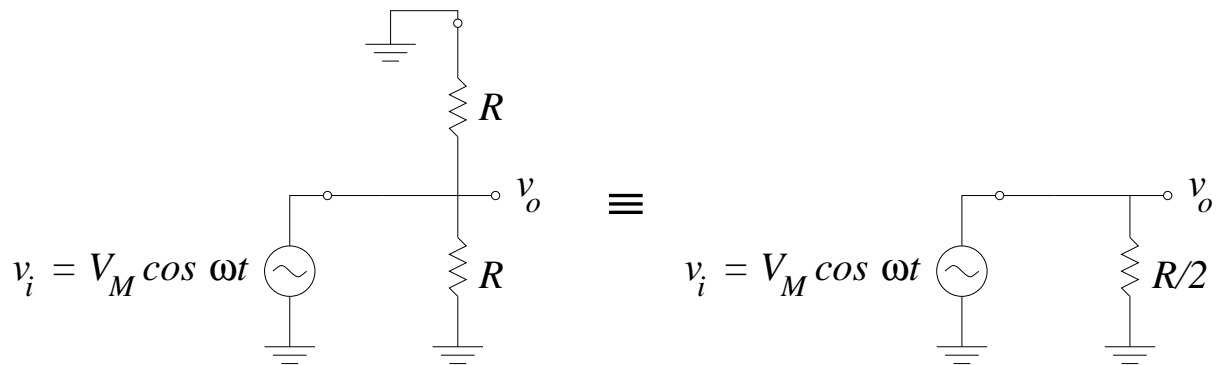

Therefore, the AC component at the output is  $v_o = v_i$  and the total output voltage is  $v_o = V_{DC}/2 + v_i$ . In other words, the circuit performs the function of adding a DC value to a signal from a voltage source. Note that the total voltage drop across the capacitor is always  $V_{DC}/2$ .

## Preliminary work

Study Section 7.2 in the textbook. Practice finding time constants, using the dB scale, and drawing Bode plots.

In the laboratory, you will investigate the following circuit.

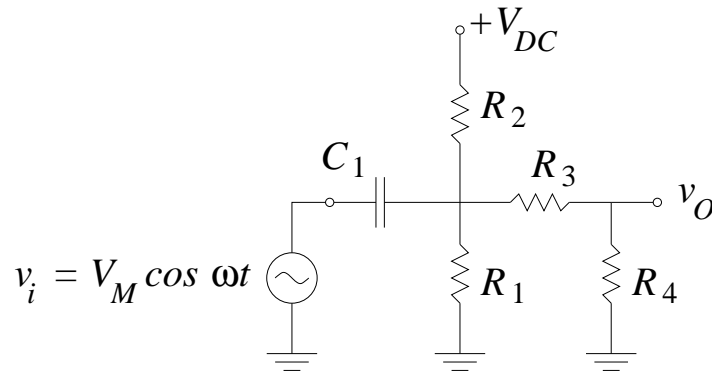

The component values are given as  $R_1 = 2.2 \text{ k}\Omega$ ,  $R_2 = 1.8 \text{ k}\Omega$ ,  $R_3 = R_4 = 1.0 \text{ k}\Omega$ , and  $C_1 = 1 \text{ }\mu\text{F}$ . The DC voltage supply has  $V_{DC} = 5 \text{ V}$  and the signal generator has a peak-to-peak amplitude of  $0.8 \text{ V}$  (i.e.,  $V_M = 400 \text{ mV}$ ).

When doing calculations for the preliminary work, first find an expression (a formula) in terms of the circuit parameters, and then substitute the numerical values given above to find the numerical result. This will make finding mistakes much easier.

1. Solve the DC circuit and find the DC voltage at the output.
2. Draw the AC equivalent circuit.
3. Calculate the corner frequency.
4. Determine the frequency range for which the capacitor can be considered a short circuit.
5. Determine the small-signal AC voltage gain  $A_v = |V_o|/|V_i|$  for an input signal whose frequency is much higher than the corner frequency.
6. Draw the Bode plot (asymptotic approximation) for the voltage gain (in dB scale).
7. Write the total output voltage  $v_o$  as a sum of its DC and AC components for frequencies that are much higher than the corner frequency.
8. Do a PSPICE simulation of this circuit to determine all DC voltages and currents (Bias Point Analysis), and compare these with your calculations of Part 1.
9. Do a PSPICE simulation of this circuit to generate a plot of the output signal  $v_o$  versus frequency  $f$  (AC Sweep Analysis). The frequency axis should be logarithmic and span

the range 1 Hz – 10 kHz. Generate two frequency plots, one with a linear axis for  $v_o$ , and the other with a logarithmic axis. Compare with your Bode plot of Part 6.

As you see, in this circuit the output voltage is an AC signal riding on top of a DC component. Now suppose we need to get rid of the DC component of the output to have a pure AC signal. We can use a second coupling capacitor for this purpose. Consider the following circuit where the value of  $C_2$  is given as 10  $\mu\text{F}$ . Analyzing this circuit is not very easy since there are now two capacitors.

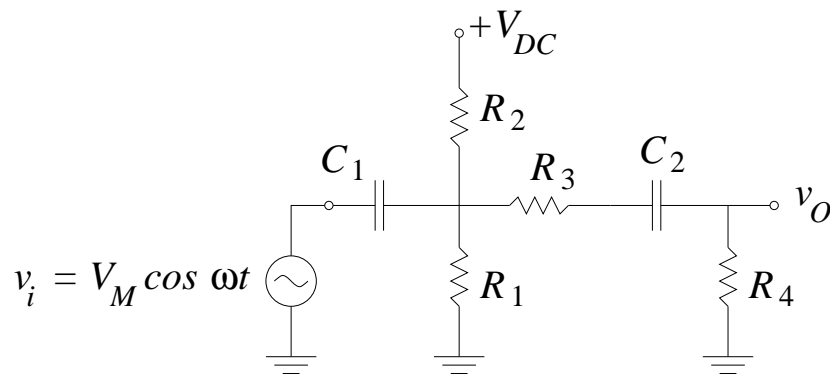

10. Do a PSPICE simulation of this circuit to determine all DC voltages and currents.
11. Do a PSPICE simulation of this circuit to generate a plot of the output signal  $v_o$  versus frequency  $f$ . The frequency axis should be logarithmic and span the range 1 Hz – 10 kHz. Generate two frequency plots, one with a linear axis for  $v_o$ , and the other with a logarithmic axis. Compare with the frequency plots of Part 9.

## Experimental work

1. Construct the first circuit given in the preliminary work section.

*The capacitor that you use here is an electrolytic capacitor, i.e., it has a predefined polarity. Make sure you connect the positive terminal of the capacitor towards the DC power supply.*

2. Before connecting the signal generator, measure all DC voltages with a multimeter and verify that your circuit is operating as expected.
3. Connect the signal generator. Set the voltage at the input to 0.8 V p–p and the frequency to 10 kHz. Repeat the DC voltage measurements of the previous part to check that DC voltages have not changed.

*When you set up the signal generator, always verify the output waveform using an oscilloscope. The actual output voltage may be different than that indicated on the signal generator itself.*

4. Observe the input and output voltages on the oscilloscope on two separate channels. Measure the peak-to-peak amplitude and the DC value at the output. Determine the AC voltage gain, and compare it with the value calculated in your preliminary work.

*When taking measurements with the oscilloscope, pay particular attention to whether a channel is AC coupled or DC coupled. If you want to see the total waveform, set the channel to DC coupled. If you want to zoom in on the AC signal only, set the channel to AC coupled.*

5. Gradually decrease the input signal frequency as you watch the AC component of the output signal. Determine the corner frequency by noting the point at which the voltage gain drops to 71% ( $1/\sqrt{2} = 0.71$  or  $-3$  dB) of its value at 10 kHz. Compare this measured corner frequency with the calculated value.

*Note that, the signal generator output voltage may change when you change the frequency.*

6. Generate a plot of the voltage gain versus frequency. To do this, take a number of data points in the 10 Hz – 10 kHz range (at least 10 data points). At each frequency point, measure the voltage gain and note the phase difference between the input and the output waveforms.
7. Bring the frequency back to 10 kHz and set up the oscilloscope in  $X$ - $Y$  mode. This generates an input–output graph on the screen. Note that since the input and the output are in phase, the oscilloscope renders a straight line. Now gradually decrease the signal generator frequency and note the changes on the oscilloscope screen due to changes in the phase difference.
8. Find the frequency at which the phase difference between the input and the output is  $\pi/4$  using the oscilloscope in  $X$ - $Y$  mode.