

Design Charts to Maximize the Gain-Bandwidth Product of Capacitive Micromachined Ultrasonic Transducers

Selim Olcum, Muhammed N. Senlik, Can Bayram and Abdullah Atalar
 Dept. of Electrical and Electronics Engineering
 Bilkent University
 Ankara, Turkey 06800
 Email: selim@ee.bilkent.edu.tr

Abstract—In this work we define a performance measure for capacitive micromachined ultrasonic transducers (cMUT) in the form of a gain-bandwidth product to investigate the conditions that optimize the gain and bandwidth with respect to device dimensions, electrode size and electrical termination resistance. For the transmit mode, we define the figure of merit as the pressure-bandwidth product. Fully-metallized membranes achieve a higher pressure-bandwidth product compared to partially metallized ones. It is shown that the bandwidth is not affected by the electrode size in the transmit mode. In the receive mode, we define the figure of merit as the gain-bandwidth product. We show in this case that the figure of merit can be maximized by optimizing the electrode radius. We present normalized charts for designing an optimum cMUT cell at the desired frequency with a given bandwidth for transmit or receive modes. The effect of spurious capacitance and liquid loading effect are considered. Design examples are given to clarify the use of these charts.

I. INTRODUCTION

It is shown that a large bandwidth is possible with an untuned cMUT immersed in water [1], [2]. For such a cMUT, the operation frequency range may extend from very low frequencies to the antiresonance of the membrane [3]. However, those cMUTs have small conversion efficiencies and are not as sensitive as piezoelectric transducers. In this work, we explore the limits of a cMUT operating in different regimes using the Mason model corrected with finite element method (FEM) simulations. We try to maximize the bandwidth of a cMUT while keeping the output pressure or the conversion efficiency at a reasonable value. For this purpose, we define performance measures in the form of a pressure-bandwidth product or a gain-bandwidth product. We try to maximize this figure of merit by optimizing various geometrical parameters of the cMUT.

II. MASON MODEL

Commonly, a numerical analysis of cMUTs is based on the Mason's equivalent circuit model. This lumped model has been utilized in many studies before [1], [2]. The equivalent circuits of a cMUT in transmit (a) and in receive (b) modes are demonstrated in Fig. 1, where C_0 is the capacitance between the electrodes, C_S is the parallel spurious capacitance, n is the turns ratio, Z_m is the lumped mechanical impedance

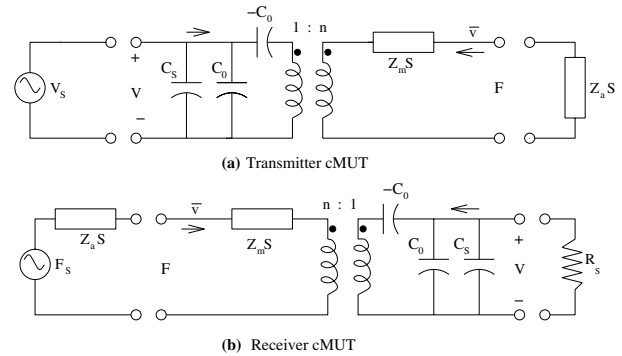

Fig. 1. Mason model (a) for a cMUT operating as a transmitter excited by a voltage source (V_S) to drive the acoustic impedance of the immersion medium ($Z_a S$), (b) for a cMUT operating as a receiver excited by the acoustical source (F_S , $Z_a S$) to drive the electrical load resistance of the receiver circuitry (R_S).

of the membrane, S is the membrane area and Z_a is the acoustical impedance of the immersion medium. A negative series capacitance $-C_0$ is included to take the spring softening effect into account. Note that, for the receive mode equivalent circuit, the electrical side is terminated with an electrical termination resistance, R_S .

The Mason Model formulations used in this paper are based on the model depicted in [4]. The differences are demonstrated below. The circuit parameters are calculated both using simple numerical calculations¹ and FEM simulations². Additionally, the effect of water loading is included in the analysis using the method in [5].

To be able to consider partial electrode cases, the turns ratio, n is calculated using the method developed in [6]:

$$n = K \frac{F_{effective}}{V_{AC}} \quad (1)$$

where K is a lumped correction factor given by $K = 0.58 \pm 0.05$.

The collapse voltage of the membrane is calculated using the method developed in [7]. An approximate formula is given

¹Numerical calculations are performed using MATLAB

²FEM simulations are performed using ANSYS

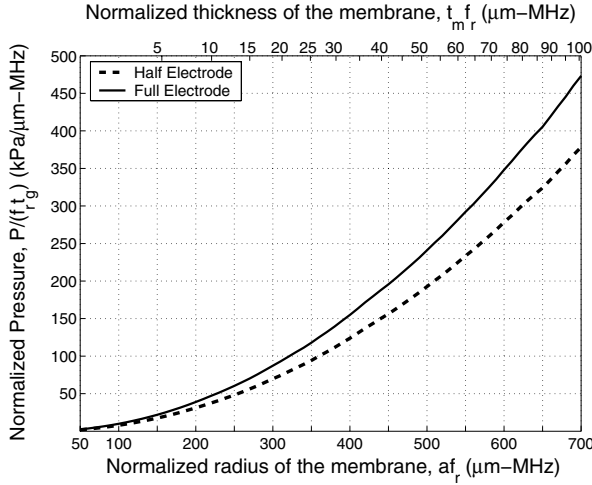

Fig. 2. Normalized pressure as a function of normalized membrane radius or thickness for transmitter cMUTs with full metallized (solid), or half metallized membranes (dashed).

below for design purposes:

$$V_{col} \simeq \gamma \sqrt{\frac{128(Y_0 + T)t_m^3 t_g^3}{27\epsilon_0(1 - \sigma^2)a^4}} \quad (2)$$

where γ is equal to 0.7 and 0.82 for full metallized and half metallized membranes, respectively.

III. PERFORMANCE OPTIMIZATION

The performance of a transducer can be maximized by optimizing the membrane radius (a), membrane thickness (t_m), gap thickness (t_g), electrode radius and the electrical termination resistance (R_S). In order to make a fair comparison, we always keep the maximum applied bias voltage at the 90% of V_{col} . Furthermore, we compare transducers with equal natural resonance frequency, f_r .

A. Transmit Mode

In the transmit mode, there is no electrical limitation on the applied voltage other than the collapse voltage of the membrane or the electrical break-down of the insulation material. The electrical mismatch between the electrical source and the transducer is not a concern. The produced pressure at the output port is the important parameter along with the 3-dB bandwidth of the output pressure, B_1 . Referring to the Fig. 1(a), we define P as the pressure in the immersion medium, $P = F/S$, when the applied AC voltage, V_S is at the maximum allowable value. Therefore, we define the figure of merit for transmit mode as:

$$M_T = PB_1 \quad (3)$$

B. Receive Mode

In the case of receive mode, the input signal power is limited. Therefore, we should utilize the available acoustical power from the source as much as possible. The mismatch losses both at the acoustical side and at the electrical side

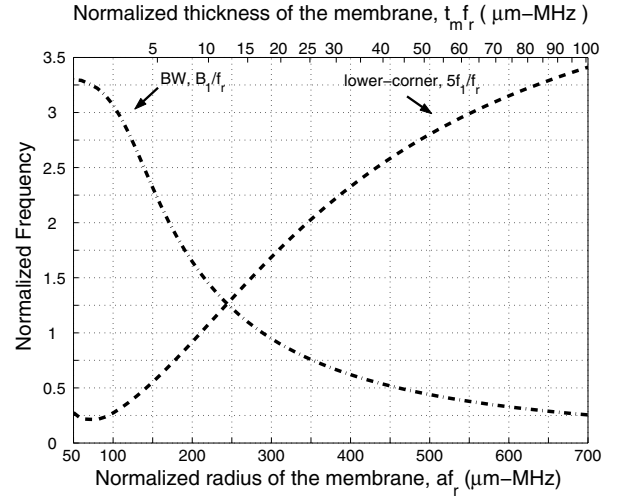

Fig. 3. Normalized bandwidth (dash-dot) and lower corner frequency (dashed) as a function of normalized membrane radius or thickness for transmitter cMUTs.

must be minimized for the maximum performance. Transducer power gain, G_T , (the ratio of power delivered to electrical load to the power available from the source) [8] takes into account the mismatch losses for both input and output ports. Using $\sqrt{G_T}$ as gain³ and B_2 as the 3-dB bandwidth of the gain, we define the gain-bandwidth product as

$$M_R = \sqrt{G_T} B_2 \quad (4)$$

IV. DESIGN GRAPHS

Utilizing the figure of merit definitions, the performance charts of cMUTs for different a and t_m values are produced. While sweeping a , t_m is also varied in order to keep f_r constant. Initially, C_S is kept at zero. It was shown in [4] that the performance of the transducers can be normalized with respect to f_r and t_g . In the following charts, all the axes are normalized and their relation with the actual values is provided in the axis labels.

For simplicity we treat the problem as if it is linear, although a cMUT is a highly nonlinear device. The resulting normalized pressure and bandwidth figures are seen in Figs. 2 and 3. We also show the effect of reducing the radius of electrode metallization by a factor of 2. Notice the trade off between the increasing pressure, P and decreasing bandwidth, B_1 as af_r increases. The resulting M_T is normalized and plotted in Fig. 4.

For the receive mode of operation, the applied bias voltage is kept constant at 90% of the collapse voltage. In this case, the figure of merit, M_R , is independent of the gap height, t_g [4]. The results of the receive mode simulations are presented in Figs. 5, 6 and 7. Note that R_S is optimally chosen for each a - t_m pair and the normalized value of R_S is plotted in Fig. 8.

We consider the effect of the spurious capacitance, C_S in Fig. 9. It is clear that existence of C_S reduces both the gain and bandwidth.

³Square root of G_T is used to get a voltage based gain.

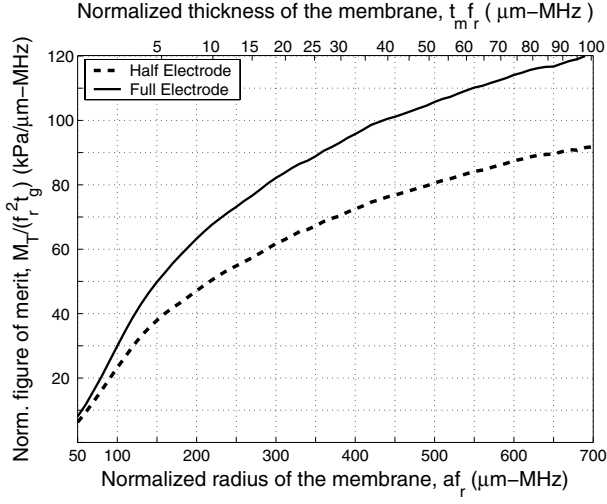

Fig. 4. Normalized pressure-bandwidth product as a function of normalized membrane radius or thickness for transmitter cMUTs with full metallized (solid), or half metallized membranes (dashed).

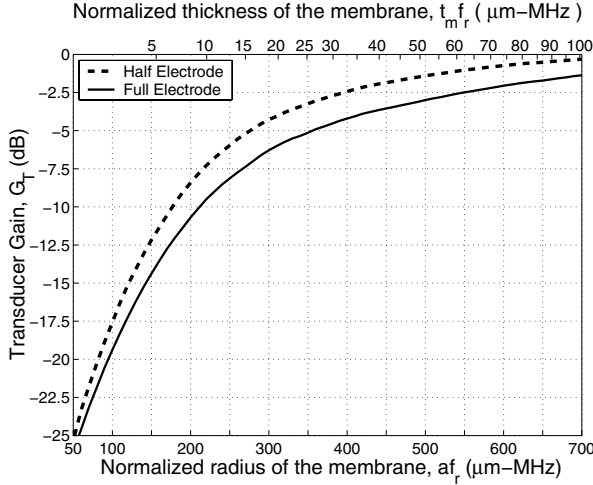

Fig. 5. Normalized transducer gain as a function of normalized membrane radius or thickness for receiver cMUTs with full metallized (solid), or half metallized membranes (dashed). The curves are independent of t_g . $C_S=0$.

V. DESIGN EXAMPLES

Let us demonstrate the use of the graphs by designing a transmitter cMUT operating between the 3-dB frequencies f_1 to f_2 with an output pressure per voltage as high as possible. Suppose $f_1=1$ MHz and $f_2=15$ MHz, meaning $B_1=14$ MHz. We first pick the point where $af_r=200$ $\mu\text{m-MHz}$ in Fig. 3. $B_1/f_r=1.65$ at this point implies $f_r=8.5$ MHz. We read $5f_1/f_r=0.9$, resulting $f_1=1.5$ MHz which is larger than the 1 MHz requirement. After a few iterations we find $af_r=175$ satisfies the specifications. In this case, $B_1/f_r=1.9$ so f_r is 7.4 MHz and $5f_1/f_r = 0.7$ with $f_1 \simeq 1$ MHz. We complete the design by calculating other parameters. The required transducer radius is $175/7.4 \simeq 24\mu\text{m}$. From the upper x-axis of Fig. 3, we determine the thickness, $6.4/7.4 \simeq t_m=0.9\mu\text{m}$. To achieve a high output pressure we should pick

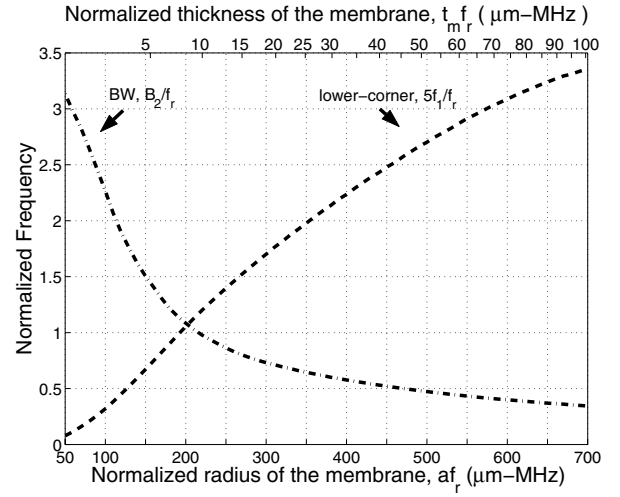

Fig. 6. Normalized bandwidth (dash-dotted) and lower corner frequency (dashed) as a function of normalized membrane radius or thickness for receiver cMUTs with full metallized or half metallized membranes. The curves are independent of t_g . $C_S=0$.

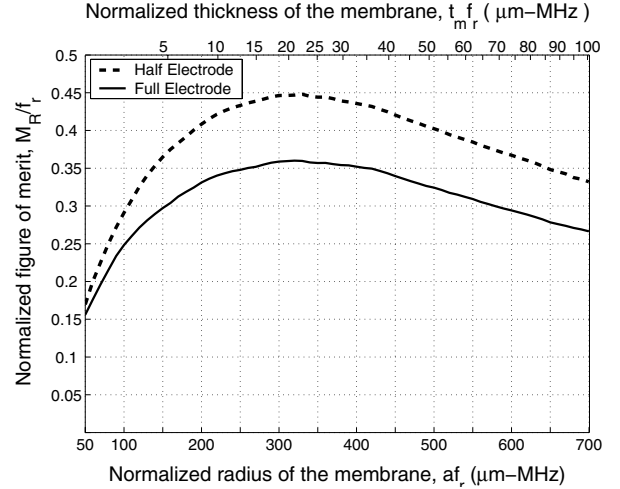

Fig. 7. Normalized gain-bandwidth product as a function of normalized membrane radius or thickness for receiver cMUTs with full metallized (solid), or half metallized membranes (dashed). The curves are independent of t_g . $C_S=0$.

the collapse voltage as high as possible. Let us assume we have a voltage source that can generate pulses up to 150 V. Hence, if $V_{col}=150$ V, from Eq. 2, effective t_g value would be calculated as $\simeq 0.5\mu\text{m}$. Using Fig. 4 the figure of merit is calculated as $58 \times 7.2^2 \times 0.5 \simeq 1500$ kPa-MHz. Since the bandwidth is 14 MHz, the output pressure $P \simeq 105$ kPa.

Suppose we need a cMUT with an output pressure of 300 kPa with a center frequency of 6 MHz. Let's use the design graphs to determine the device dimensions. If we choose $t_g=0.5$ μm and $f_r=6$ MHz, we find $P/(f_r t_g) = 300/(6 \times 0.5) = 100$. Using Fig. 2 we determine $af_r = 320$ and $t_m f_r = 21$ resulting $a = 53\mu\text{m}$ and $t_m = 3.5\mu\text{m}$. The estimated collapse voltage (Eq. 2) is calculated as 250 V. From Fig. 3 the bandwidth $B_1 = 0.85 \times 6 = 5.1$ MHz and

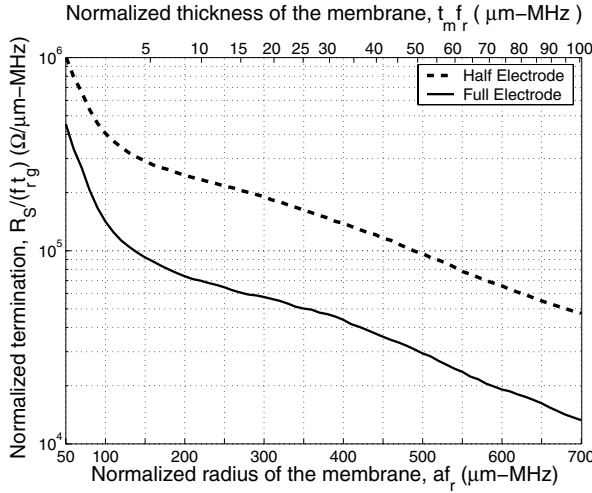

Fig. 8. Normalized termination resistance, R_S as a function of normalized membrane radius or thickness for receiver cMUTs with full metallized (solid), or half metallized membranes (dashed). $C_S=0$.

$$f_1 = 1.85 \times 6/5 = 2.2 \text{ MHz.}$$

As an example for designing a receiver cMUT, suppose we need 10 MHz bandwidth between 2 MHz and 12 MHz 3-dB corner frequencies. We decide to fabricate our transducers with a half top electrode, since we wish a higher transducer gain. Using the dashed curves we read $B_2/f_r=0.75$ for $a f_r=300 \mu\text{m-MHz}$. In this case f_r should be 13.4 MHz. For this choice, f_1 is calculated from $5f_1/f_r=1.65$ as 4.4 MHz which is above the 2 MHz requirement. After a few iterations we determine that when $a f_r=200 \mu\text{m-MHz}$, f_r is 9 MHz and it satisfies $B_2=10$ MHz and $f_1=2$ MHz. Therefore, a should be $22.5 \mu\text{m}$ and t_m should be $0.9 \mu\text{m}$. The transducer gain is determined from Fig. 5 as -8.5 dB. In order to achieve an acceptable bias voltage, we choose $t_g=0.25 \mu\text{m}$. In this case, V_{col} is calculated as $\simeq 77$ V. The termination resistance should be $230\text{K} \times 0.25 \times 9 \simeq 520\text{K}\Omega$ per transducer. Therefore, if 104 cMUTs are connected in parallel, an electrical load of 5 K Ω is necessary.

As our last example let us suppose that we want to design a transducer with a transducer gain of -3 dB centered at 8 MHz. Utilizing Fig. 5, we determine when $a f_r=360$ the gain requirement is satisfied. At this point $B_2/f_r=0.65$ and $5f_1/f_r=2$ (Fig. 6). In order to achieve $f_1 + B_2/2=8$ MHz, we set $2f_r/5 + 0.65f_r/2=8$ MHz or $f_r=11$ MHz and $f_1=4.4$ MHz. Since we determined f_r , $a \simeq 33 \mu\text{m}$, $t_m=2.6 \mu\text{m}$. For a gap height of $0.25 \mu\text{m}$ collapse voltage is calculated as $\simeq 160$ V. In this case, the electrical termination resistance per cell should be $150\text{K} \times 0.25 \times 11 \simeq 410\text{K}\Omega$.

VI. CONCLUSION

We defined performance measures for cMUTs in transmit and receive modes. We presented ways of maximizing these measures considering both gain and bandwidth by optimizing the geometrical and electrical parameters. For the transmit mode, larger gap heights and electrode sizes are preferable,

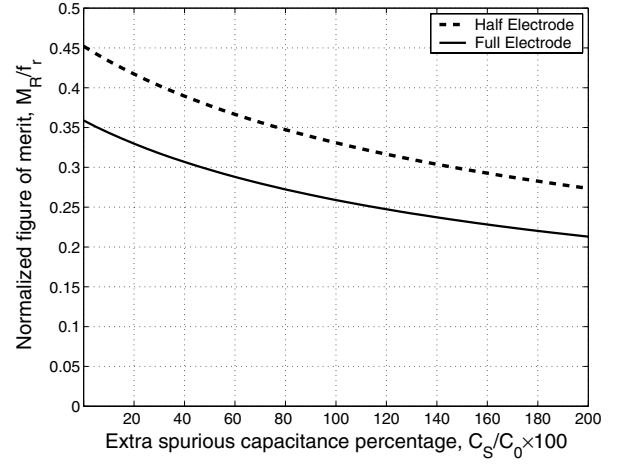

Fig. 9. Maximum value of normalized gain-bandwidth product as a function of spurious capacitance, C_S , with respect to the shunt input capacitance for receiver cMUTs with full metallized (solid), or half metallized membranes (dashed).

since higher collapse voltages and turns ratios are possible. Additionally, smaller membrane radii result in higher bandwidth at the expense of pressure and pressure-bandwidth product. For the receive mode, the gap height does not effect the performance. Half metallized membranes are optimum if spurious capacitors are negligible. Additionally, there is an optimal value for radius or thickness and electrical termination resistance for a given resonance frequency. For very high bandwidth values, gain and the gain-bandwidth product must be sacrificed. An electrical spurious capacitor is detrimental for the performance of cMUT in receive mode. We introduce design tools to determine the optimum dimensions and electrical parameters for a given frequency response.

REFERENCES

- [1] I. Ladabaum, X. Jin, H. T. Soh, A. Atalar, and B. T. Khuri-Yakub, "Surface micromachined capacitive ultrasonic transducers," *IEEE Trans. Ultrason., Ferroelect., Freq. Contr.*, vol. 45, pp. 678–690, 1998.
- [2] A. Bozkurt, I. Ladabaum, A. Atalar, and B. T. Khuri-Yakub, "Theory and analysis of electrode size optimization for capacitive microfabricated ultrasonic transducers," *IEEE Trans. Ultrason., Ferroelect., Freq. Contr.*, vol. 46, pp. 1364–1374, 1999.
- [3] G. G. Yaralioglu, M. H. Badi, A. S. Ergun, and B. T. Khuri-Yakub, "Improved equivalent circuit and finite element method modelling of capacitive micromachined ultrasonic transducers," in *Proc. of 2003 Ultrasonics Symposium*, pp. 469–472, 2003.
- [4] S. Olcum, M. N. Senlik, and A. Atalar, "Optimization of the gain-bandwidth product of capacitive micromachined ultrasonic transducers," to be published in *IEEE Trans. Ultrason., Ferroelect., Freq. Contr.*, 2005.
- [5] A. Lohfink, P. C. Eccardt, W. Benecke, and M. Meixner, "Derivation of a 1D cMUT model from FEM results for linear and nonlinear equivalent circuit simulation," in *Proc. of 2003 Ultrasonics Symposium*, pp. 465–468, 2003.
- [6] C. Bayram, S. Olcum, M. N. Senlik, and A. Atalar, "Bandwidth improvement in a cMUT array with mixed sized elements," in *Proc. of 2005 Ultrasonics Symposium*, 2005.
- [7] A. Nikoozadeh, B. Bayram, G. G. Yaralioglu, and B. T. Khuri-Yakub, "Analytical calculation of collapse voltage of cMUT membrane," in *Proc. of 2004 Ultrasonics Symposium*, pp. 256–259, 2004.
- [8] D. Pozar, *Microwave Engineering*. New York: John Wiley and Sons, 1998.