

EEE 314 DIGITAL ELECTRONICS

LAB # 2

Prelab

Consider the unloaded ECL buffer-inverter circuit shown in Figure 1. Also consider the ring oscillator configuration shown in Figure 2.

Part 1 : Hand Calculation

Determine and plot voltage transfer characteristics using hand calculations for the ECL buffer-inverter. The transistors in the circuit are BC238 ($\beta=300$, $V_{BEA}=0.7$, $V_{CEsat}=0.2$, $V_{BEsat}=0.8$).

Part 2 : SPICE Simulations

In this part, you can use 5SPICE+SPICEOPUS for the questions regarding ECL buffer voltage transfer characteristics and PSPICE for the ring oscillator simulations.

- 1) Determine and plot voltage transfer characteristics using 5SPICE for the ECL buffer-inverter. You can use the available model for transistors (BC238) as given in the course web page .
- 2) As you have previously done in the first lab, apply a convenient rectangular voltage pulse at the input and simulate the ECL buffer-inverter to find the values of for t_{fall} , t_{rise} (Check Figure 3 for the definitions of t_{fall} , t_{rise}).
- 3) Measure the power dissipation of the ECL buffer-inverter by calculating the current drawn from the power supply for the cases when $V_{in}=\text{high}$ and $V_{in}=\text{low}$.
- 4) Simulate the ring oscillator configuration. Observe the effect of the capacitance loading at the output of the inverters with different choices of capacitance values (C1...C7). Due to your selection of the capacitance values, the ringing frequency will change accordingly. Clearly indicate the highest and the lowest achievable frequencies of the ringing oscillations that you have found by loading with distinct capacitive values. You may use the available models in PSPICE libraries for 7404 inverters and 7400 NAND gate. Vcontrol voltage and the NAND gate are inserted into the circuit, just for convenience to force the nodes to desired voltages. Apply periodic rectangular pulses (between 0 and 5 Volts) with 1Mhz frequencies for Vcontrol with duty cycle of %50.

Lab Manual

1) ECL Buffer Inverter

- a) Build the inverter and measure the voltage transfer characteristics using the x-y feature of an oscilloscope with a low frequency input signal (1 kHz).
- b) Plot the experimental, hand calculated and SPICE results together for comparison.
- c) Apply a rectangular voltage pulse at the input (eg. 100kHz) and note down the transition times at the inverted output node for transitions both from low to high and high to low.
- d) Measure the power dissipation your circuit.

2) Ring Oscillator

You will be supplied with different kinds of inverters belonging to;

- HCMOS family
- LSTTL family

Sequentially, build the ring oscillator circuits for these two kinds of inverters as given in Figure 2. For each of the inverter types, you will investigate the capacitive loading effects and finally you are going to make speed and power consumption comparisons.

- a) Build your circuit first with an HCMOS inverter type. Apply a rectangular 1 Mhz control signal (between 0 and 5 Volts) from the function generator. With the following loading capacitor values:

- 2.2 pF
- 15 pF
- 52 pF
- 100 pF

observe the ringing oscillations. Note down the specific frequencies of the ringing oscillations with each loading capacitor value.

Loading Capacitor Value (pF)	Oscillation Frequency
2.2	
15	
52	
100	

- b)** With a 15 pF loading capacitor, measure the power dissipation.
- c)** Now, build your circuit with an LSTTL inverter type. Again, apply the 1 Mhz control signal from the function generator. Note down the oscillation frequencies for this configuration.

Loading Capacitor Value (pF)	Oscillation Frequency
2.2	
15	
52	
100	

- d)** With a 15 pF loading capacitor, measure the power dissipation for this circuit as well.
- e)** With all the data in your hand, comment about the speed of both inverter types. Compare their power dissipation values.

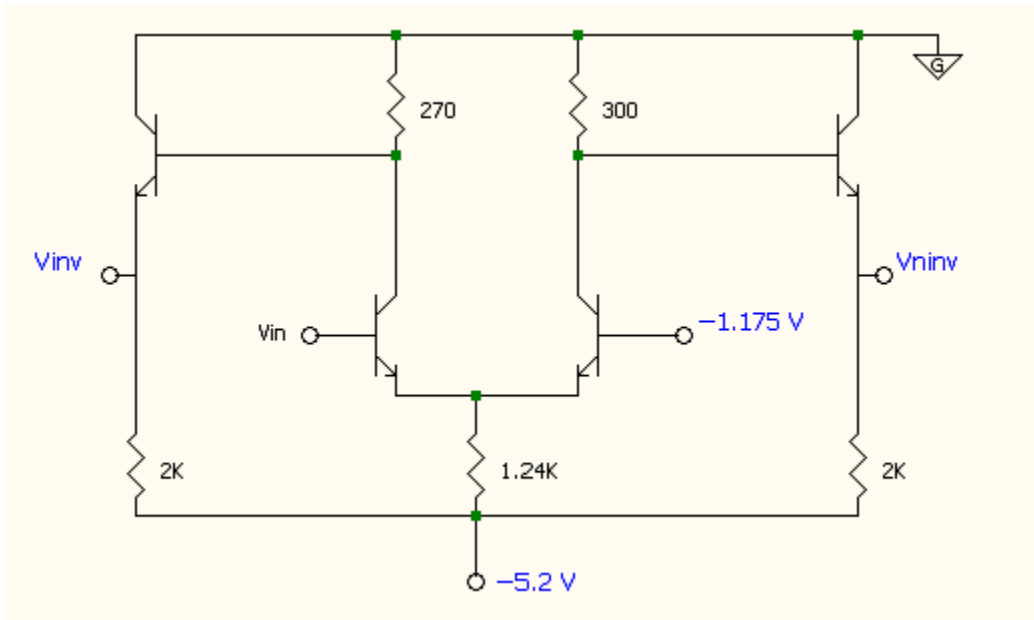

Figure 1 ECL Buffer Inverter Circuit

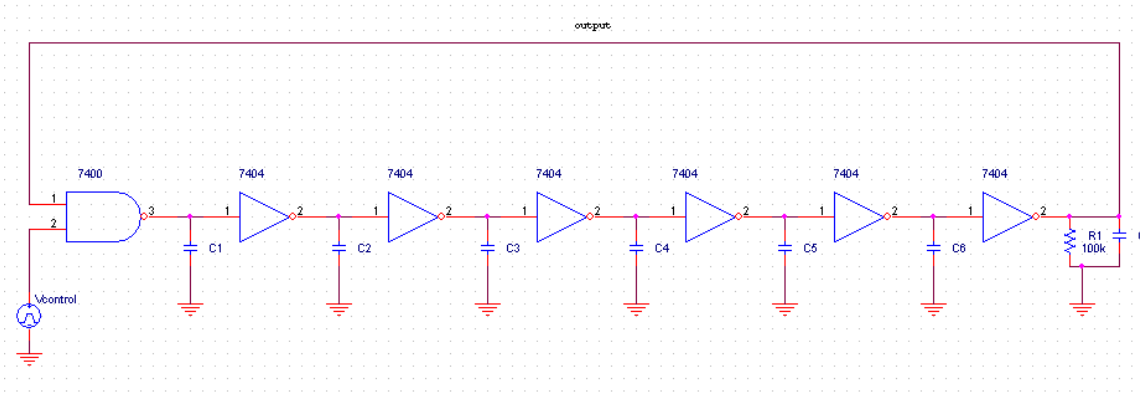

Figure 2 Ring Oscillator Configuration

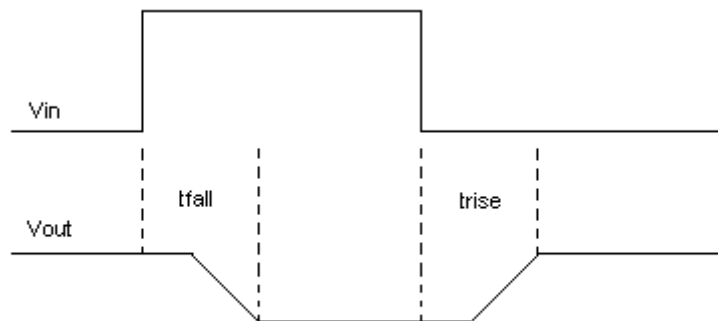

Figure 3 Definitions for t_{fall} and t_{rise}