

DIRECT SEQUENCE SPREAD SPECTRUM COMMUNICATIONS SYSTEM IN A MULTIPATH FADING CHANNEL. RAKE RECEIVER PERFORMANCE ANALYSIS

A. Szabo, A. M. Manolescu

Polytechnic University of Bucharest, Bd. Iuliu Maniu 1-3, Bucharest, Romania

A. Alsolaim

Ohio University, Electrical and Computer Engineering, Athens, OH 45701, USA

M. Glesner

Inst. of Microelectronic Systems, Darmstadt Univ. of Technology, Karlstr.15, D-64283 Darmstadt Germany

ABSTRACT

The use of direct sequence spread spectrum (DS-SS) baseband modulation in a mobile communication system have proved to bring many advantages. In this paper a study of the DS-SS modulation and its performances in a multipath fading channel is presented, considering different parameters for the system and communication channel. A RAKE receiver is implemented to achieve diversity over the different path arrived at the receiver. The numerical results were obtained using Matlab simulations. The results of the simulations indicate the utility of reconfigurable hardware implementation for the receiver, the diverse functioning conditions imposing diverse configurations.

I. INTRODUCTION

The code division multiple access (CDMA) communications have more and more importance in the personal mobile communications field because of their numerous advantages e.g. spectral efficiency, multipath protection and availability of time diversity, message privacy, easy identification of the subscriber, low radiated power density.

The CDMA communications systems are based on the DS-SS baseband data modulation. This implies that the signal's spectrum is expanded, i. e. the signal energy is distributed over a much larger bandwidth than the minimum one required for transmission. In direct sequence spread spectrum (DS-SS), the signal is spreaded by multiplying it by a pseudonoise (PN) sequence with a much higher chip rate (the elements of the PN sequence are referred as chips). In the transmitter, the signal is multiplied by the spreading sequence which causes a spectral spreading of the original narrow band signal. In the receiver, the signal is multiplied by the (complex conjugated) spreading sequence again. If the reference sequence of the receiver is synchronised to the data modulated PN sequence in the received signal, the original signal can be recovered. The principles of DS-SS are described in details in [1, 3].

The RAKE is a special technique of receiver that takes advantage of the multipath propagation. If the time spread of the channel is greater than the time resolution of the system then different propagation paths can be separated and the information extracted from each path can be used to increase the signal to noise ratio (SNR). The time spread of the channel is given by the maximum delay between the arrival of transmitted signal on different propagation paths; the time resolution of the system is given by the inverse of the bandwidth of the radio frequency

signal, or equivalent by the chip period of the PN sequence. Descriptions of this type of receiver and implementation can be found in references as [2, 6, 7].

The RAKE receiver is composed of two or more correlation arms, which extract the signals, arrived on different propagation paths. This is possible because the correlation between two versions of the PN sequence delayed by one or more chips is almost zero, so the propagation paths are separable.

In Chapter 2 the communications system is presented and the theoretical analysis is performed. Chapter 3 presents the simulation parameters and gives numerical results. In the last Chapter the conclusions from the analysis and simulations are presented as well as the future work to develop the system.

II. SYSTEM PRESENTATION.

The communication link shown in Fig.1 is assumed:

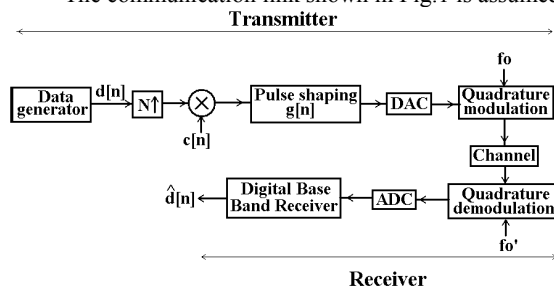

Fig. 1. System model

The data generator offers the input data for the system, -1 or +1 bits distributed randomly.

For spreading a complex PN sequence is used:

$$c[n] = c_1[n] + j^* c_2[n], \quad (1)$$

where $c_1[n], c_2[n] \in \{-1, +1\}$ and $j^2 = -1$.

The data rate (R_d) is N times smaller than the chip rate (R_c), where N is the spreading gain:

$$N = R_c/R_d. \quad (2)$$

This imposes that the data sequence $d[n]$ is oversampled N times in the block before spreading.

The spreaded signal is then pulse shaped with a digital FIR filter, having the advantage of easier implementation and reconfigurability. The continuous time pulse shape filter used is the Square Root Raised Cosine (SRRC) pulse, with the roll off factor variable $\beta \in [0, 1]$. The non causal impulse response of the filter is described in [2] and [8]:

$$g(t) = \frac{\sin[(1-\beta)\pi \cdot t/T_c] + 4\beta \cdot t/T_c \cdot \cos[(1+\beta)\pi \cdot t/T_c]}{\pi \cdot t/T_c [1-(4\beta \cdot t/T_c)^2]} \quad (3)$$

which has the particular values:

$$g(0) = 1 - \beta + 4\beta \cdot \pi \quad (4)$$

$$g\left(\frac{T_c}{4\beta}\right) = \frac{\beta}{\sqrt{2}} \cdot \left[\left(1 + \frac{2}{\pi}\right) \cdot \sin\left(\frac{\pi}{4\beta}\right) + \left(1 - \frac{2}{\pi}\right) \cdot \cos\left(\frac{\pi}{4\beta}\right)\right] \quad (5)$$

where $T_c=1/R_c$ is the chip period.

For a FIR implementation of the transmitter pulse shape filter, $g(t)$ must be delayed, truncated and sampled:

$$g[n] = \begin{cases} g\left(\frac{n \cdot T_s}{\lambda} - \frac{\delta \cdot T_c}{2}\right) & \text{for } 0 \leq n \leq \delta \cdot \lambda \\ 0, & \text{otherwise} \end{cases} \quad (6)$$

where λ is the oversampling factor and δ is the FIR filter length, δ being a natural odd number. An over sampling of the pulse shape filter is required to obtain a smooth transition between the data symbols after the digital to analogue conversion (DAC).

Next, the signal is radio frequency (RF) quadrature modulated with the carrier provided by a local oscillator and then passed through the channel.

The channel is modeled as a frequency selective Rayleigh fading channel, with a number of $L=\text{int}(BW \cdot T_d)$ separable paths, where BW is the bandwidth of the transmitted signal and T_d is the time spread of the channel. The simulation model is the tapped delay line model, presented in Fig. 2:

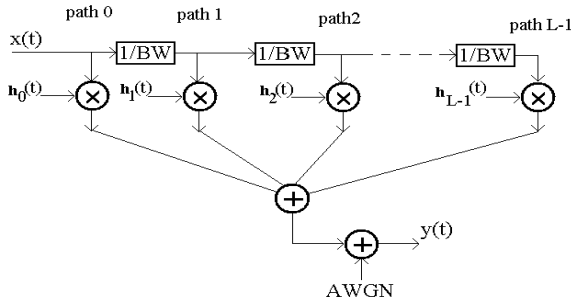

Fig. 2. Tapped delay line model of the channel

The coefficients $h_0(t), h_1(t), \dots, h_{L-1}(t)$ are the complex impulse response of the channel which multiplies the incoming signal in every path of the tapped delay line model. Since the signals from the paths is added as random vectors, the amplitude of each term will appear to be Rayleigh-distributed and the phase uniformly distributed. This is the most commonly accepted model [1, 2].

The fluctuations in the magnitude of the complex envelope due to the Doppler effects must be also taken in consideration. The principle to generate a Rayleigh fading envelop is presented in Fig. 3.

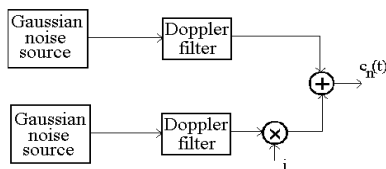

Fig. 3. Principle to generate a Rayleigh fading envelope

In the receiver, the signal is RF demodulated, using a replica of the carrier which presents an instantaneous phase error a . Then it is sampled, analogue to digital converted by the ADC block and finally enters the digital baseband receiver, presented in Fig. 4.

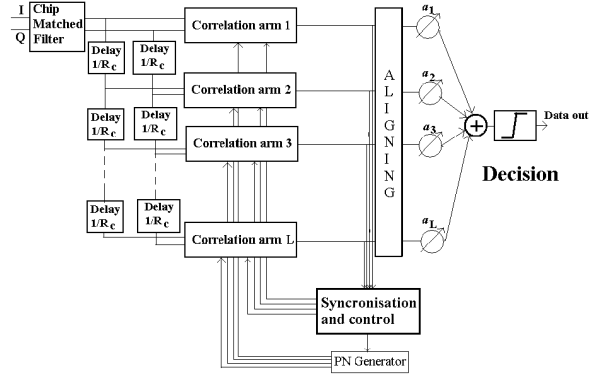

Fig. 4. Digital RAKE Receiver

The chip matched filter has the same impulse response as the pulse shaping in the transmitter, so that the resulting filtering of the two is a Raised Cosine (RC) filter. This will give a zero inter symbol interference for perfect sampling moment.

The correlation arms perform the correlation with the synchronized replica of the PN sequence used in the transmitter. Its diagram is presented in Fig. 5.

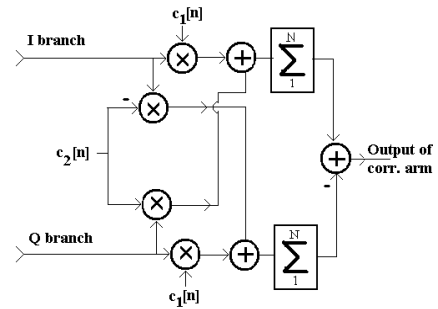

Fig. 5. Correlation arm

The digital receiver is composed of L correlation arms, each arm extracting the information from the same input signal, just delayed with one chip. Using for each arm the same PN sequence, the separation between propagation paths is possible.

To achieve a lower bound on the error probability for the coherent RAKE receiver, a scaling of the correlation arms output is needed. Supposing a perfect synchronisation, to obtain an optimum coherent combining, the scaling coefficients must fulfil Maximum Ratio Combining (MRC) requirements, i.e. will maximise the signal to noise ratio (SNR) of the decision signal. MRC studies can be found in [9], and the well-known result has to be used:

$$a_i = k \cdot |h_i(t)| \quad (7)$$

where k is a real positive constant and $|h_i(t)|$ is the attenuation coefficient of the channel.

The decision is made considering that the data is BPSK modulated, so:

$$\hat{d}[n] = \text{sign}\left(\sum_1^L \alpha_i \cdot d_i^c[n]\right), \quad (8)$$

where $d_i^c[n]$ is the output of the i^{th} correlation arm.

III. SIMULATIONS SETUP AND RESULTS.

The simulations are intended for the future third generation mobile communications systems, so high data rates are supposed, up to 2Mbps; spreading gains are $N=8\dots 1024$.

The simulations had the purpose to point out the dependence of the performances of the receiver on the communication parameters and the implementation of the receiver. To achieve this a flexible program was written using Matlab environment. The program computes the bit error rate (BER) for a communication having as parameters the signal to noise ratio (SNR), the spreading gain, number of fingers of the receiver and number of bits of quantisation used in the digital receiver. Two cases are simulated: assuming a receiver speed of 20km/h, and considering the Doppler effect; and assuming the receiver is stationary, so the coefficients in the tapped delay line model are constant.

In this study a perfect synchronisation was supposed to observe the influence of the other parameters of the receiver. In future work a synchronisation unit is to be also simulated and analysed.

In real radio systems, the base band data is RF modulated, so the carrier frequency is much higher than the modulation signal bandwidth. For a computer added simulation, a very high sampling rate will be required, which will lead to very high computation efforts. But this can be avoided considering that in a radio RF signal the only part that contains the information is the modulation signal. A Phase Shift Keying (PSK) modulated RF signal can be expressed as:

$$x(t) = \cos(\omega_0 \cdot t + \phi(t)) = \text{Re}\{e^{j\phi(t)} \cdot e^{j\omega_0 t}\}, \quad (9)$$

where ω_0 is the carrier frequency and $\phi(t)$ is the phase modulation. As it can be seen from this formula, the whole

information to be transmitted is contained by the term $e^{j\phi(t)}$, called the-low pass equivalent. Starting from this point, a low-pass equivalent of the communication system can be built. If the condition that the bandwidth of the band pass signal is much lower than the carrier frequency is satisfied, using Hilbert transform, we can have the following equivalencies:

- **band-pass signal**->low-pass signal equivalent;
- **Band-pass filters** -> low-pass filter with the transfer function the same as the one of the band-pass filter, shifted by the carrier frequency down to the baseband, and taking just the positive part;
- **Band-pass stochastic process** -> stochastic process, with the same power in the baseband as in the radio frequency band.

The Monte Carlo method is employed for BER computing. It consists of comparing the data at the input of the system and data recovered at the output of the receiver, and counting the number of errors. The BER is equal to the number of mistaken bits divided by the total number of bits passed through the system.

The number of data bits passed through the system was 10^5 , number relatively small, so that the minimum BER that could be estimated is 10^{-5} . The number of simulated bits was limited by the computing power limitations.

The results of the simulations are presented as graphical representations of the dependence of the bit error rate to the signal to noise ratio, having as parameter the spreading gain, the number of quantisation bits and the number of fingers in the RAKE receiver.

a) BER dependence on the SNR.

Two simulations were performed, one for an analogue RAKE receiver, and one for a digital RAKE receiver with 6 bits quantisation per sample.

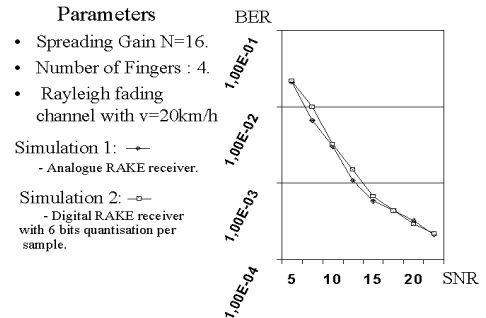

Fig. 6. BER(SNR) – analogue/digital implementation

From this figure we can conclude that the quantisation noise in the digital implementation does not worsen much the BER, the results of the simulation being similar.

b) BER dependence of the SNR having the speed on the mobile as parameter.

Two simulations were performed, one for a stationary channel and one assuming the mobile speed is 20km/h.

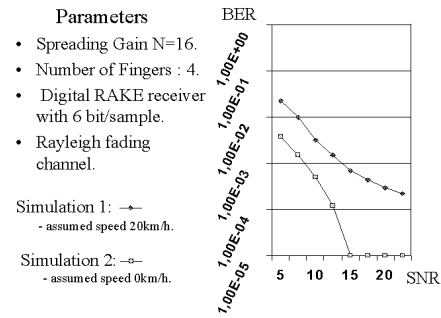

Fig. 7. BER(SNR)–dependence on the mobile speed

From this figure relevant is the important dependence of the bit error rate to the speed of the mobile and the characteristics of the channel. In the simulation for stationary mobile, for SNR greater than 13dB the BER is smaller than 10^{-5} , so the simulation could not establish the exact BER.

c) BER dependence on the number of quantisation bits.

Two simulations were performed, one for SNR = 5dB, another for SNR = 10dB.

If the number of the quantisation bits is increased, naturally the bit error rate decreases. But, this decreasing is limited to the BER obtained by the analogue implementation

(without a quantisation). For more than 6 bits/sample the improvement of the performances does not satisfy the hardware requirements. For large signal to noise ratios the number of quantisation bits can be decreased down to 4 or less.

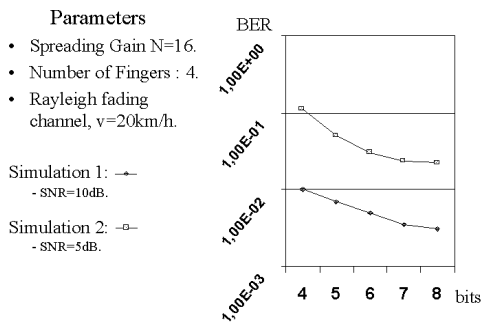

Fig. 8. BER (number of quantisation bits)

d) BER dependence on the number of correlation arms. Two simulations were performed, one for SNR = 15dB, another for SNR = 10dB.

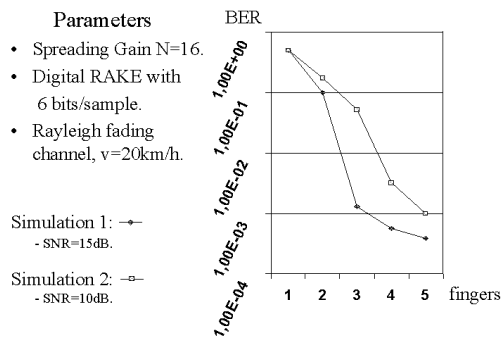

Fig. 9. BER (number of fingers)

In this figure the benefits of the RAKE technique are illustrated. The normal receiver, that doesn't use this diversity technique, has a very high bit error rate, close to 0.5, that means no information recovered at all. Also we can see that, as the number of fingers increases, the improvement is limited, so a number of fingers greater than 4 means a hardware effort that is not justified. This depends on the number (L) of separable paths. For this simulation $L=6$ separable path were considered.

e) BER dependence on the spreading gain (N). Two simulations were performed, one for SNR = 15dB, another for SNR = 5dB.

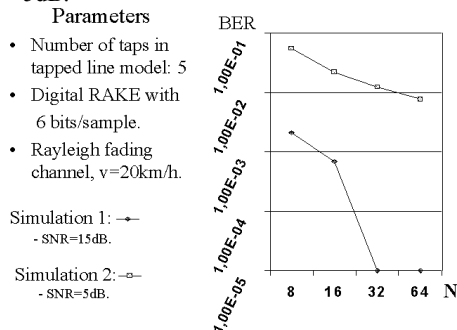

Fig.10. BER (Spreading Gain)

From figure 10 we can see how the performances are improved when the spreading gain increases. The benefits are clearer for high signal to noise ratio values.

IV. CONCLUSIONS.

The presented simulations show the influence of the considered parameters on the DS-SS communication system and the digital RAKE receiver behaviour.

The results of the simulations indicate the utility of reconfigurable hardware implementation for the receiver, the diverse functioning conditions imposing diverse configurations for the receiver, as the number of correlation arms, the number of quantisation bits or the spreading gain.

To further develop this study the following topics must be also discussed:

- Synchronisation and Control Unit.
- Coding of the Data and its influence on the performances of the system.
- Optimisation of the correlation process.

REFERENCES

- [1]. Andrew J. Viterbi – “Principles of Spread Spectrum Communication” – Addison Wesley 1998.
- [2]. Jhong Sam Lee, Leonard E. Miller – “CDMA Systems Engineering Handbook” – Artech House Publishers 1998.
- [3]. Kamilo Feher – “Wireless Digital Communications” – Prentice Hall 1997.
- [4]. G. J. R. Povey, P.M. Grant – “Simplified matched filter receiver designs for spread spectrum communications applications” – “Electronics & Communication Engineering Journal” 1993.
- [5]. R. Zimmerman, M. Neeracher – “SHIVA: Correlator / Demodulator Chip for Direct Sequence Spread – Spectrum RAKE – Receiver” – ETH Zurich 1994.
- [6]. R. Prince, P. E. Green Jr., “A Communication Technique for Multipath Channels”, Proc. IRE, vol. 46, pp. 555-570, Mar. 1958.
- [7]. J. S. Lehnert, M. B. Pursley, “Multipath Diversity Reception of Spread Spectrum Multiple-Access Communications”, “IEEE Transactions on Communications”, vol. COM-35, pp. 1189-1198, Nov. 1987.
- [8]. J. A. Cadzow, “Foundations of Digital Signal Processing and Data Analysis”, Macmillan Publishing Company, 1987.
- [9]. J. K. Proakis, “Digital Communications”, McGraw – Hill, 1989.